

*Strength Building Gear*

837101

**WEIGHT STACK ATTACHMENT**

**PRODUCT ASSEMBLY  
INSTRUCTIONS SHEETS**

1  
12/01/95

**837101 WEIGHT STACK ATTACHMENT ASSEMBLY PARTS LIST**

**SORT AND COUNT ALL PARTS BEFORE BEGINNING ASSEMBLY**

**HARDWARE:**

ITEM	NAME/DESCRIPTION	QTY
1.	3/8 X 3 IN. BOLT .....	1
2.	1/2 X 2-3/4 IN. BOLT .....	2
3.	3/8 X 2-3/4 IN. BOLT .....	1
4.	3/8 X 1-1/2 IN. BOLT .....	1
5.	1/2 IN. WASHER .....	1
6.	3/8 IN. WASHER .....	2
7.	1/2 IN. LOCK WASHER .....	1
8.	3/8 IN. LOCK WASHER .....	1
9.	1/2 IN. LOCK NUT .....	1
10.	3/8 IN. LOCK NUT .....	2
11.	WEIGHT STACK SELECTOR PIN .....	1
12.	3/8 IN. FLANGE SPACER.....	2
13.	3 X 2 IN. END CAP .....	2
14.	2 IN. SQ. COVER CAP .....	1
15.	WEIGHT STACK CUSHION .....	2
16.	WEIGHT PLATE BUSHING .....	40
17.	3/8 X 2 IN. NYLON BOLT .....	2

**WELDMENTS/PARTS:**

ITEM	NAME/DESCRIPTION	QTY
1.	<u>PULLEY HOUSING WELDMENT</u> .....	1
2.	<u>WEIGHT STACK BASE WELDMENT</u> .....	1
3.	<u>1-3/4 SQ. X 18-1/4 IN. TUBE</u> .....	1
4.	<u>GUIDE ROD</u> .....	2
5.	WEIGHT PLATE .....	20
6.	HEAD PLATE .....	1
7.	WEIGHT STACK SHAFT .....	1
8.	4-1/2 X 1 IN. PULLEY .....	1
9.	CABLE (6577701) .....	1

**NOTE: BOLT LENGTH IS MEASURED FROM THE UNDERSIDE OF THE HEAD OF THE BOLT.**

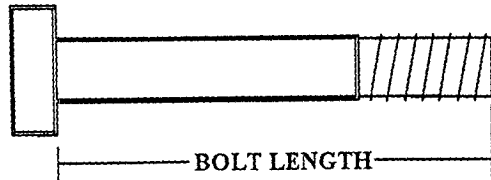

**BOLT LENGTH RULER:**



## 837101 WEIGHT STACK ATTACHMENT ASSEMBLY INSTRUCTIONS

### THANK YOU

FOR PURCHASING THE 837101 WEIGHT STACK ATTACHMENT. PLEASE SAVE THESE ASSEMBLY INSTRUCTIONS FOR YOUR PERSONAL REFERENCE, AND ADDITIONAL SERVICE INFORMATION.

### \*\*\*IMPORTANT\*\*\*

- IF YOU EXPERIENCE ANY PROBLEM WITH THE ASSEMBLY OF THIS PRODUCT, PLEASE CONTACT YOUR DEALER OR YOUR PARABODY CUSTOMER SERVICE REPRESENTATIVE AT: 1-800-328-9714
- **TOOLS REQUIRED:** RATCHET, 3/4 SOCKET or WRENCH, 9/16 SOCKET or WRENCH, ADJUSTABLE WRENCH, and RUBBER Mallet or HAMMER

1. Remove *LAT BAR WELDMENT* from the HIGH PULLEY CABLE, and set aside. Loosen and remove the three (3) 3-1/2 X 1 IN. PULLEYS from the *BOOM WELDMENT*. Detach HIGH PULLEY CABLE from the *CARRIAGE WELDMENT* and remove.
2. Loosen and remove *BOOM WELDMENT* from the *FRONT and REAR UPRIGHT WELDMENT*. Remove the 2 IN. SQ. END CAP from the top of the *REAR UPRIGHT WELDMENT*. Remove the *CARRIAGE WELDMENT* from the *REAR UPRIGHT WELDMENT*.
3. Insert the 1-3/4 SQ. X 18-1/4 IN. TUBE into the top of the *REAR UPRIGHT WELDMENT* as shown in (VIEW B), then **SECURELY** re-assemble the *BOOM WELDMENT* to the *REAR UPRIGHT WELDMENT* as shown.
4. Route CABLE (6577701) through the front slot and down to the rear slot of the *BOOM WELDMENT*. Re-assemble two (2) of the three (3) 3-1/2 X 1 IN. PULLEYS to the *BOOM WELDMENT* as shown on the (CABLE ROUTING DIAGRAM). (NOTE: **MAKE SURE CABLE IS IN THE GROOVE OF THE PULLEYS**). **SECURELY** re-assemble the *BOOM WELDMENT* to the *FRONT UPRIGHT WELDMENT*.
5. **SECURELY** assemble the *PULLEY HOUSING WELDMENT* to the 1-3/4 SQ. X 18-1/4 IN. TUBE as shown in (VIEW B)
6. Slide one (1) 2 IN. SQ. COVER CAP over the end of the *WEIGHT STACK BASE WELDMENT*, then **SECURELY** assemble it to the *BASE WELDMENT* as shown in (VIEW A) (NOTE: **THE LOW PULLEY CABLE MUST BE ASSEMBLED EXACTLY THE WAY SHOWN TO ENSURE PROPER FUNCTION**)
7. Insert the *GUIDE RODS* into the holes of the *WEIGHT STACK BASE WELDMENT* as shown, and allow them to tilt back. (NOTE: **LUBRICATE GUIDE RODS WITH A SILICON OR TEFLON SPRAY THAT IS AVAILABLE AT MOST HARDWARE STORES**). Slide two (2) WEIGHT STACK CUSHIONS down over the *GUIDE RODS* as shown.
8. **SECURELY** assemble the WEIGHT STACK SHAFT to the HEAD PLATE as shown on drawing. Also insert the WEIGHT PLATE BUSHINGS into the WEIGHT PLATES as shown in (DETAIL C).

## 837101 WEIGHT STACK ATTACHMENT ASSEMBLY INSTRUCTIONS

---

9. **USING EXTREME CARE** slide the WEIGHT PLATES down over the GUIDE RODS onto the WEIGHT STACK CUSHIONS as shown. (MAKE SURE THAT THE KEY HOLES OF THE WEIGHT PLATES ARE ALL FACING THE SAME WAY) Slide the HEAD PLATE ASSEMBLY down over the GUIDE RODS onto the WEIGHT STACK as shown.
10. Tilt the GUIDE RODS back up underneath the PULLEY HOUSING WELDMENT and insert the 3/8 X 2 IN. NYLON BOLTS through the PULLEY HOUSING WELDMENT and into the ends of the GUIDE RODS as shown in (VIEW B)
11. Loosen and remove the top PULLEY from the PULLEY BLOCK and replace it with the 4-1/2 X 1 IN. PULLEY.
12. **SECURELY** assemble the remaining PULLEY from the BOOM WELDMENT, and the swapped PULLEY of the PULLEY BLOCK to the PULLEY HOUSING WELDMENT as shown in (VIEW B).
13. **HIGH PULLEY CABLE ROUTING ASSEMBLY (SEE CABLE ROUTING DIAGRAM):**
  - A. Route the end of the CABLE under, and around the 4-1/2 X 1 IN. PULLEY of the PULLEY BLOCK, and back up through the BOOM WELDMENT to the large hole of the PULLEY HOUSING WELDMENT.
  - B. Route the CABLE through the hole and over and around the two PULLEYS in the PULLEY HOUSING WELDMENT. Run the cable down through the large hole above the WEIGHT STACK and down to the WEIGHT STACK SHAFT of the HEAD PLATE.
  - C. Thread the end of the CABLE into the end of the WEIGHT STACK SHAFT.
  - D. Insert the 3 X 2 IN. END CAPS into the ends of the PULLEY HOUSING WELDMENT as shown in (VIEW B).
14. Re-attach LAT BAR WELDMENT to the HIGH PULLEY CABLE.
15. Attach the WEIGHT STACK LABELS to the WEIGHT STACK as shown in (DETAIL C).
16. To select WEIGHT, rotate the WEIGHT STACK SELECTOR PIN clock wise 90 degrees, insert into the slot of the desired WEIGHT PLATE, and rotate the PIN back down.

DASH NO	DESCRIPTION
01	AS SHOWN

REVISIONS				
REV	DESCRIPTION	CHG NO	APP'D	DATE
A	NEW RELEASE	2737	DLM	10/95
B	CHG VIEW B	2758	DLM	12/95

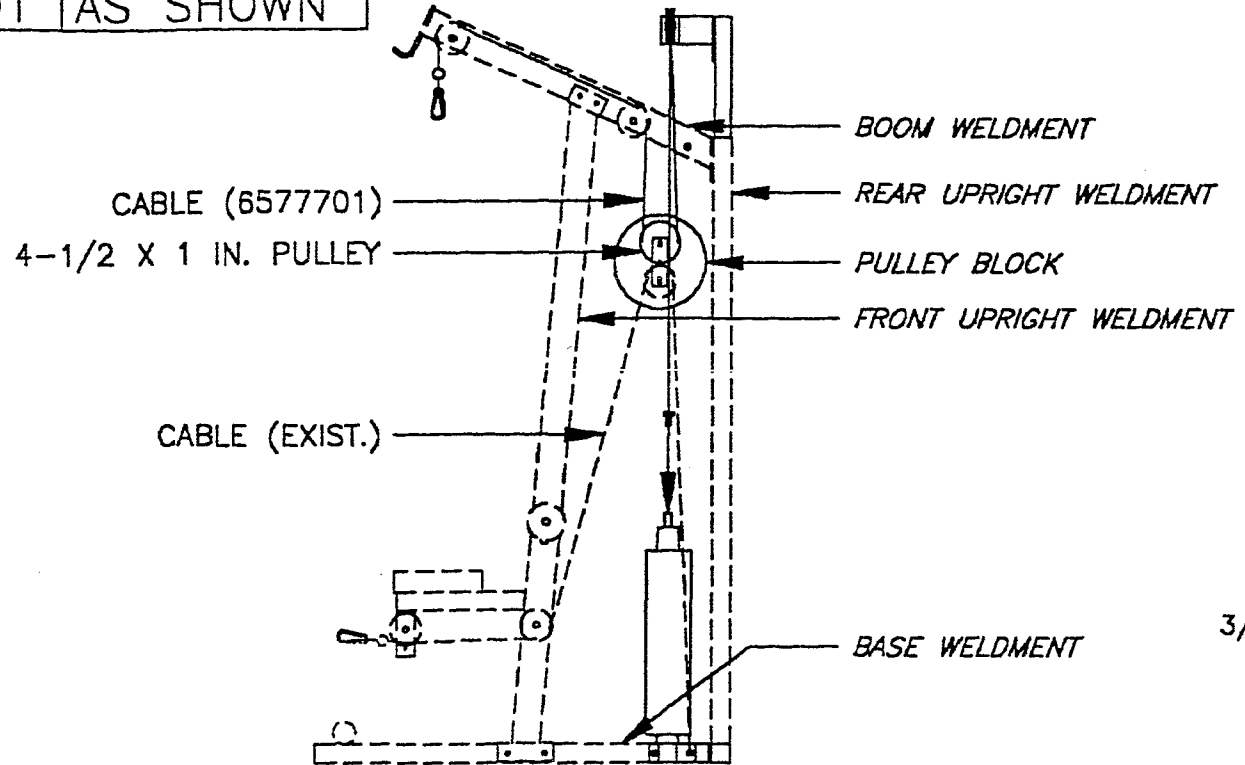

CABLE ROUTING DIAGRAM

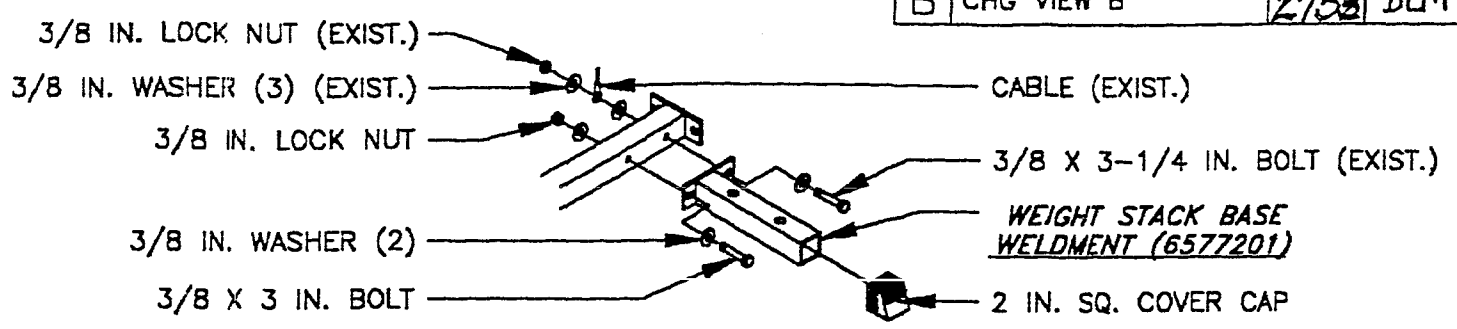

VIEW A

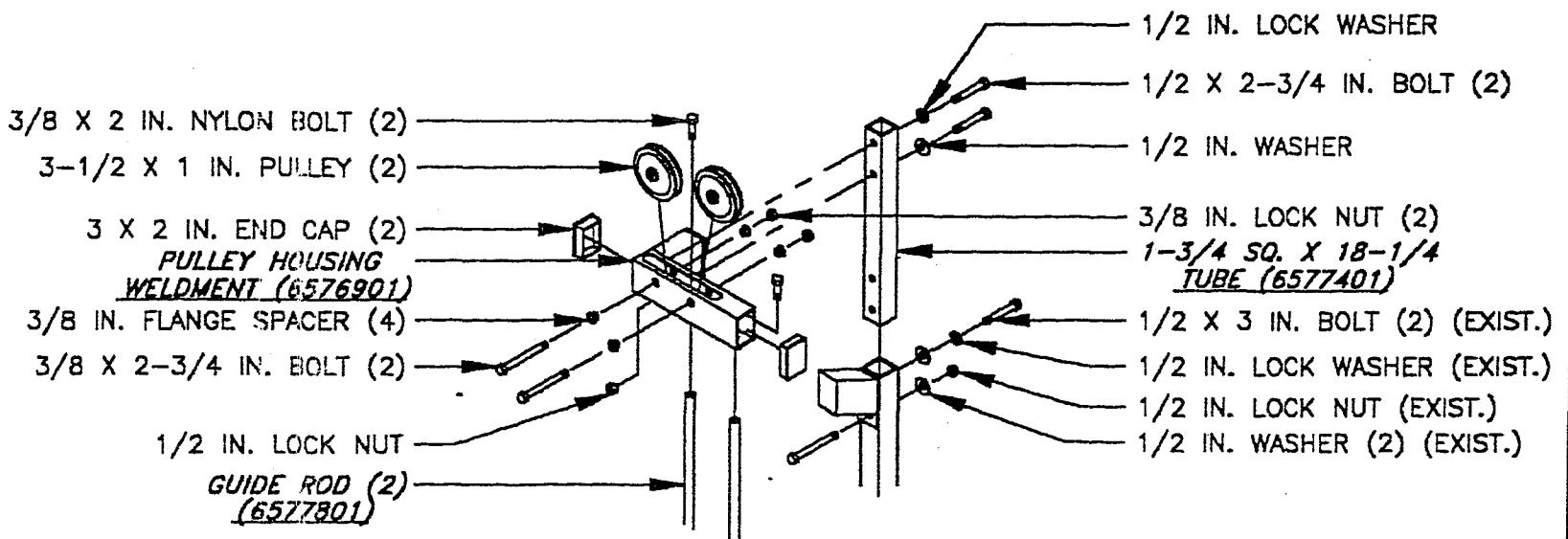

VIEW B

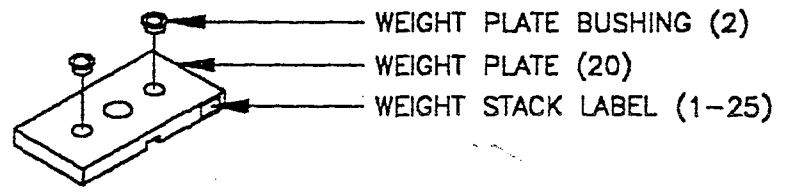
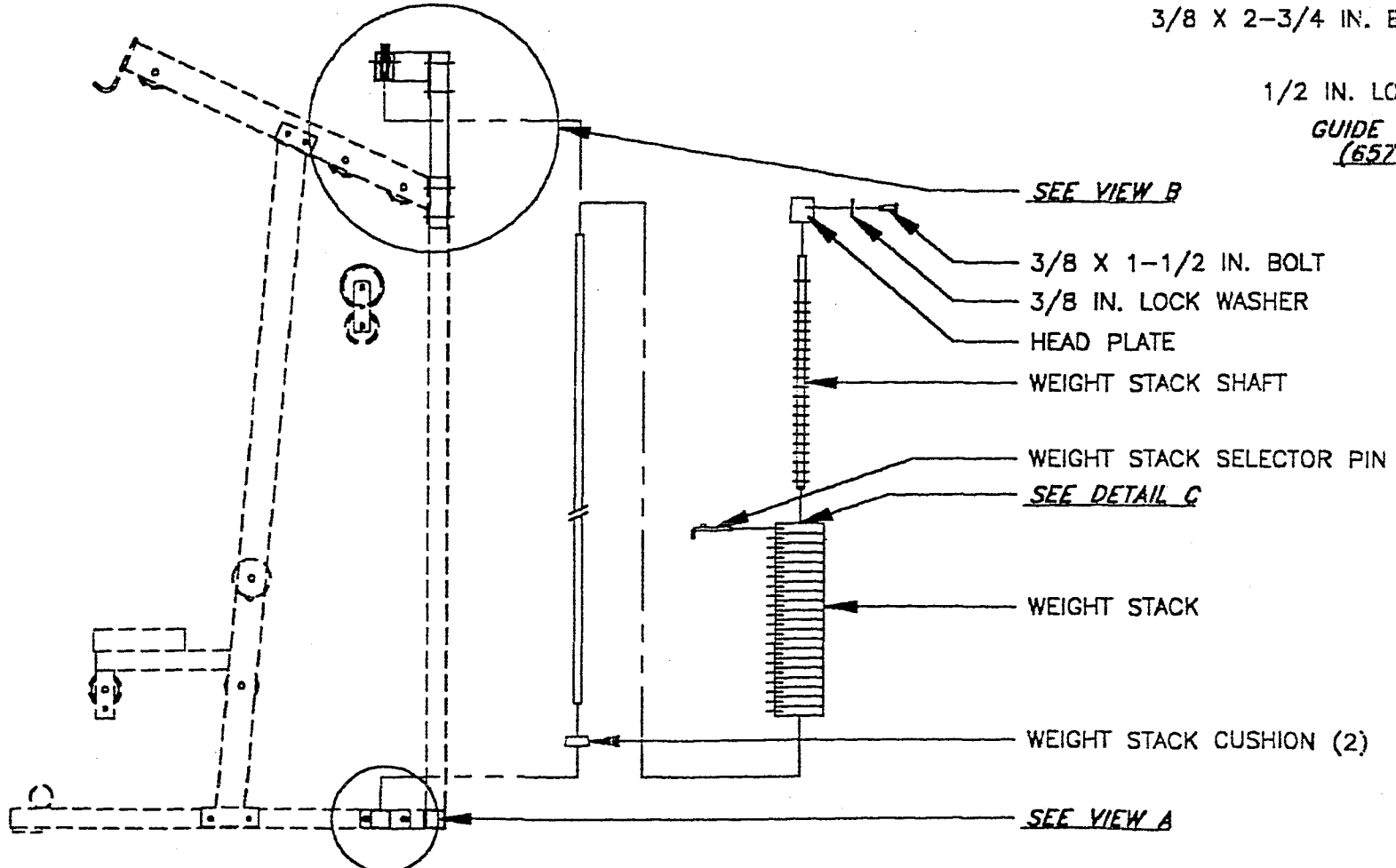

DETAIL C

TOLERANCES (EXCEPT AS NOTED)		<h1>PARABODY, INC.</h1> <p>RAMSEY, MINNESOTA</p>			
DECIMAL	~				
FRACTIONAL	± 1/16	TITLE		ASSY INST, 837101	
ANGULAR	± 1°	SCALE	1/16	SIZE	DRAWING NO.
		SHEET	1 OF 1	B	65785
		DR	MGN	10/95	CHK'D
			MGN	10/95	APP'D
			DLM	10/95	